

M 802048/011/QCL7C

Dimensions

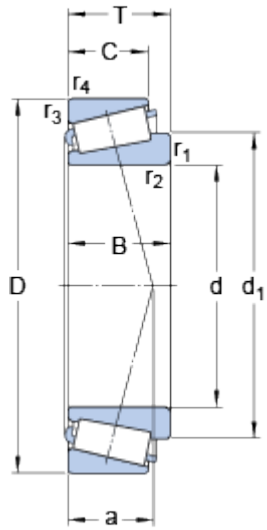

d		41.275	mm
D		82.55	mm
T		26.543	mm
d ₁	≈	62.35	mm
B		25.654	mm
C		20.193	mm
r _{1,2}	min.	3.5	mm
r _{3,4}	min.	3.3	mm
a		22	mm

Abutment dimensions

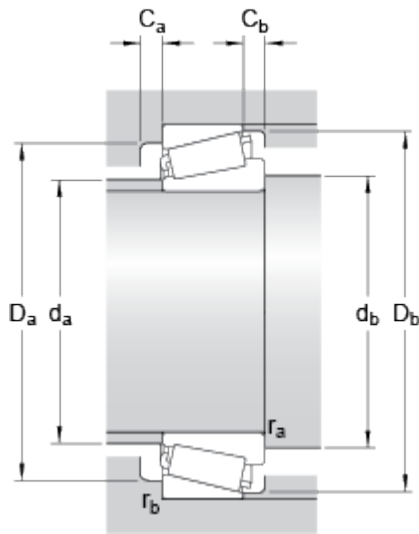

d _a	max.	50	mm
d _b	min.	52.5	mm
D _a	min.	66	mm
D _a	max.	71	mm
D _b	min.	78	mm
C _a	min.	4	mm
C _b	min.	6	mm
r _a	max.	3.3	mm
r _b	max.	3.1	mm

Calculation data

Basic dynamic load rating	C	73.7	kN
Basic static load rating	C ₀	91.5	kN
Fatigue load limit	P _u	10.6	kN
Reference speed		6000	r/min
Limiting speed		9000	r/min
Calculation factor	e	0.54	
Calculation factor	Y	1.1	

Calculation factor

Y_0

0.6

Mass

Mass bearing

0.623

kg